

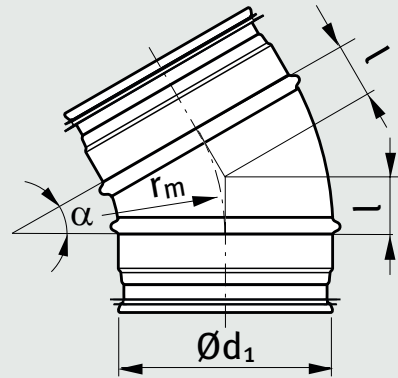

30° PRESSET BØJNING

BL 30



$$r_m \approx 1 \cdot d_1$$

MATERIALE

- galvaniseret stål
- EPDM gummiliste (BL)

PRODUKTEGENSKABER

- presset
- trådsvejst
- gummiliste (BL) er placeret med ombukket kant

Ød ₁ nom	l mm	vægt kg	kassemængde
80	27	0,15	55
100	27	0,18	75
125	33	0,20	40
140	36	0,36	30
150	40	0,35	25
160	43	0,32	20
180	48	0,51	16
200	54	0,62	18